



FEATURES

- UNIVERSAL INPUT, 5 kHz, CAN POWER THE SENSOR
- SIMPLIFIED MENUS AND PROGRAMMING
- NO NEED OF AMPLIFIERS OR LINEARIZERS
- SEVEN DIGIT RATE WITH PROGRAMMABLE DECIMAL PLACES
- THREE TOTALS UP TO 9 DIGITS WITH PROGRAMMABLE DECIMAL PLACES.
- SINGLE KFACTOR OR 10 POINT CALIBRATION CURVE
- KFACTORS FROM 0.00001 TO 9,999,999
- MILLILITERS, LITERS, GALLONS, CUBIC FEET, CUBIC METERS, ACRE FEET
- PER SECOND, PER MINUTE, PER HOUR, PER DAY
- ISOLATED 12 BIT ANALOG 4-20 mA PASSIVE OUTPUT
- ISOLATED NO POLARITY 100V/100mA DC/AC OUTPUT THAT CAN BE PROGRAMMED TO BE RATE ALARM (HIGH OR LOW) OR PULSE OUTPUT, UP TO 480 PULSES PER MINUTE (METERING PUMPS)
- ALL SETTINGS STORED IN A NON-VOLATILE MEMORY
- SEPARATE LOCK FOR THE KFACTOR ONLY
- SETTINGS LOCK/UNLOCK FOR SECURITY
- HIGH CONTRAST IN THE ENTIRE TEMPERATURE RANGE
- SIMPLE PROGRAMMING, SMALL SIZE

APPLICATIONS

- FLOW RATE AND TOTAL MEASUREMENT AND CONTROL
- METERING PUMPS PRECISE CONTROL FOR DOSING APPLICATIONS
- SCADA

1. DESCRIPTION

GFC114 is a low power flow computer / totalizer with an universal input and very simple menu structure and programming. It provides power for many types of sensors and accepts their signal to measure flow rate and total. GFC114 has an isolated no polarity 100V/100mA DC/AC output that can be programmed to work as a rate alarm, high or low, with +/- 1 % hysteresis or a pulse output. GFC114 also has an isolated 12 bit analog 4-20 mA passive output that can be connected to SCADA, PLC or another control device.

For better accuracy GFC114 provides calibration curve capabilities for up to 10 points. In seconds the operator can switch between a single KFACTOR and the curve of up to 10 points.

GFC114 has a version in one inch wider enclosure – GFC114E.

The GFC114 software implements a version of our proprietary predictive/adaptive, self-adjusting digital filtering which provides very stable reading at any input frequency, plus very fast response to any change in the flow.

GFC114 is the perfect solution for flow measurement and control applications that require high accuracy and reliability, high isolation, multi-functionality, small size, industrial grade performance and low maintenance.



2. ABSOLUTE MAXIMUM RATINGS *

Operating temperature	-20 °C to +70 °C The electronics system is industrial (-40 °C to +85 °C) and higher grade . The Liquid Crystal Display (LCD) limits the temperature range.
Power supply voltage	40 VDC
Voltage for the analog output	40 VDC
Sensor consumption	10 mA DC
Digital output current	100 mA DC/AC. Alarm, batch, limit or pulse output
Digital output voltage	100 V DC, 70V AC. Alarm, batch, limit or pulse output

* **NOTE: Stresses above those ratings may cause permanent damage to the device.**

3. CHARACTERISTICS

Parameter	Conditions	Min	Typical	Max	Units
Power supply	-20 °C to +70 °C	12		36	V DC
Input					
Voltage for the sensor	-20 °C to +70 °C, max 10 mA, Note 1		10		V DC
Threshold, low	Wave or logical signal (CMOS, TTL etc.)		1.2		V DC
Threshold, high	Wave or logical signal (CMOS, TTL etc.)		1.6		V DC
Coil voltage	Symmetrical signal from the coil (sine, triangle, saw etc)	20			mVpp
NAMUR, low threshold	-20 °C to +70 °C, Powered by GFC114, Note 2		1		mA DC
NAMUR, high threshold	-20 °C to +70 °C, Powered by GFC114, Note 2		2.1		mA DC
Reed switch current	-20 °C to +70 °C, Powered by GFC114, Note 2			3.5	mA DC
Frequency	Note 5		5 000		Hz
Analog Output					
Power supply	-20 °C to +70 °C, Note 3	7.2		36	V DC
Resolution	-20 °C to +70 °C, 7.2 – 36 V		4		uA
Error	250 ohm load, 24 V, 25 °C, Note 4			0.05	% FS
Power supply error	7.2-36V, no load, output disabled, 25 °C			0.5	uA/V
Temperature coefficient	-20 °C to +70 °C, 24 V		35		ppm/°C
Current, output disabled	SET4 = 0.0, SET20 = 0.0, 24 V DC supply, 25 °C		3.85		mA
Digital Output					
Output ON resistance	-20 °C to +70 °C, 100 mA			8	ohm
Output OFF leakage	-20 °C to +70 °C, 100 V DC			5	nA
Pulse rate				480	p/min
Pulse duration			62.5		ms
Pause duration		62.5			ms

Note 1: When powering a 3 wire sensor like open drain/collector pnp/npn sensor. For 2 wire sensors the current is automatically limited when powered by GFC114.

Note 2: If the 2 wire sensor uses external power, the external voltage must be 10 V DC or less.

Note 3: The minimum voltage for the 4-20 mA output to operate is $V = 7.2 + R \text{ load [ohm]} * 0.020$ [V DC]
For a GFC114 with a load of 250 ohm, the minimum voltage would be 12.2 V DC.

Note 4: The parameter includes all errors, non-linearity and noise at constant voltage and temperature.

Note 5: The value is for reference only. The maximum frequency strongly depends on the duty cycle of the signal and the type of the

sensor.

3.1. BUTTONS

There are three buttons: **SET** , **UP**  and **RIGHT**  :

- **SET** is used to enter and exit menus and confirm options chosen
 - **UP** is used to change the data
 - **RIGHT** is used to move the cursor (blinking digit or icon) to the right
- Additional button functions:

There are two types of buttons accepted by the GFC114 flow computer / totalizer:

- Short is when the button is pressed and released in less than 0.5 second
- Long is when it is kept pressed for more than 5 seconds
- All other durations are ignored

NOTE: The UP button will not change the value if the settings are locked.

3.2. INPUT

GFC114 has a universal pulse input from a flow sensor such as wave, logical signal, open drain/collector, npn/pnp, reed switches, dry contact, proximity/NAMUR sensors, Data Industrial 2 wire flow meters, turbine meters, coils and others. The computer / totalizer has all pull-up/down, current limiting and signal conditioning circuits built-in. The input also provides power for all types of sensors. There is no need to use external amplifiers for the coils if they provide more than 20 mVpp signal.

3.3. OUTPUTS

GFC114 has two isolated outputs:

3.3.1. Analog output

The isolated analog output is 4-20 mA, two wire, passive, 12 bit, with reverse polarity and surge protection, high accuracy and reliability. Using the **SET4** and **SET20** menus, it can be programmed to represent the flow rate.

SET4 parameter refers to the flow rate at which the output will be 4.00 mA and **SET20** sets the flow rate for 20.00 mA. If **SET4** is greater than **SET20** the output will be inverse.

3.3.2. Digital output

The isolated digital output has no polarity, can work with 100V/100mA and can be programmed to be:

- Rate alarm, high or low, with +/- 1% hysteresis.
Example: If the alarm is programmed at 100.00 GPM and to be **high** the output will turn on when the flow rate exceeds 101.00 GPM and will turn off when it drops below 99.00 GPM.
With **low** alarm the action will be reversed.
- Pulse output. It is intended for use with metering/dosing pumps, SCADA, PLCs and other devices and provides pulses with duration of 62.5 ms and pause longer than 62 ms. The output pulse rate is limited to about 480 pulses per minute for use with metering/dosing pumps.



Example: You are adding chlorine or fertilizer to the water and have connected the control input of a pump to this pulse output. You program the “**SETP**” = 3.762 Gallons per pulse. The pump will produce one pulse every 3.762 gallons and add the chlorine or the fertilizer in an exact proportion to the water.

3.4. DISPLAY

The liquid crystal display (LCD) has 7 digits with 1, 2, 3, 4 or 5 decimal places and many icons. It shows rate, total and all the variables and options that can be set or programmed. The rate and the totals have programmable auto, none, 1, 2, 3, 4 or 5 decimal places.

GFC114 software implements our latest proprietary algorithms for predictive / adaptive, self-adjusting digital filtering of the rate. It provides very stable reading at any input frequency, plus very fast response to any change in the flow.

When the display shows rate, a “**RATE**” icon is displayed. If it shows total a “**TOTAL**” icon will be displayed along with “**A**”, “**B**” or “**C**” (GFC114 has three totals).

When input pulses are present, an “**INP**” (input) icon will be displayed.

When the digital output is ON an icon for cause will be displayed (**alarm** or **pulse**)

Total A reset can be enabled or disabled but total B and C are non-resettable.

If total A is on the LCD and it is allowed to be reset, a “**RESET**” icon will be displayed.

3.4.1. Volume and time units

- Milliliters (**mL**), liters (**L**), gallons (**G**), cubic feet (**CF**), cubic meters (**M³**) and acre feet (**AF**) per second (**S**), minute (**M**), hour (**H**) and day (**D**) are available.

3.4.2. Normal mode

Automatically after turning the power on or exiting a menu, GFC114 enters the normal mode.

Normal mode displays:

- Rate
- Total A, B or C. Total A reset can be enabled or disabled. All three totals are stored in a non-volatile memory every 50 seconds or immediately when cleared.
If total A is allowed to be reset, the **RESET** icon is shown. Reset total A with long **RIGHT** button.
- To switch between rate, total A, B or C, use short **UP** button.

3.4.3. Menus

To enter the menus, use long **SET** button in normal mode. About 5 seconds after holding the **SET** button, the first menu will appear on the LCD:

- **KFACTOR** icon along with a blinking decimal point and the KFACTOR number is shown. The decimal places for all KFACTORs (single KFACTOR and all KFACTORs in the calibration table) can be programmed using **UP** button. KFACTORs ranging from 0.00001 to 9,999,999 can be entered this way. To move from the blinking decimal point away and start entering the KFACTOR digits use the **RIGHT** button. The main **KFACTOR** for the particular flow meter connected to the GFC114 can be entered.

If the flow meter is a Data Industrial 200 series, enter the “**K**” from the table in the meter manual for the particular size of the meter.



If the flow meter is any other type, enter its KFACTOR in **pulses per total volume unit**.

Programming whether the flow meter is a Data Industrial 200 series 2 wire meter can be done in the second level menu (look below).

Short **SET** enters the next menu.

If the meter is a Data Industrial 200, the next menu is **offset** menu.

Otherwise the next menu is **output type** menu

NOTE: the computer will not accept zero for the KFACTOR.

While in this menu pressing long **SET** when the cursor is on the digit in the middle will enter the KFACTOR lock/unlock menu. Using **UP** button the KFACTOR can be locked or unlocked. When locked it can only be viewed but not changed. Short **SET** returns back to KFACTOR menu.

- In the **offset** menu enter the number from the table in the manual of DI 200 series meters.
- In the **output type** menu choose between **alarm** and **pulse** using the **UP** button. While in this menu using long **SET** the settings lock menu can be entered where all settings except KFACTOR can be locked. This includes the output type as well. When locked the output type, alarm type, alarm setting, **SETP** and **SET20** can be viewed but not changed. Short **SET** returns back to output type menu.

Press short **SET** to move to the next menu.

* If the alarm output type has just been chosen, the next menu will be the “**alarm type**” menu where using **UP** button **high** or **low** alarm can be chosen. Press short **SET** to move to the **alarm value** menu.

* If the **pulse** output type has been chosen the next menu will be **SETP**.

- In the **output value** menu:
 - The value of the **alarm** must be in **rate volume units per time unit**
 - The value for **SETP** must be in **total volume units per pulse**

Note that the computer will not accept zero for those settings.

Press short **SET** to move to the next menu.

- In the **SET20** menu, set the flow rate (in **rate volume units per time unit**) at which you want the analog output to be 20.00 mA. The flow rate for 4.00 mA can be programmed in the **SET4** menu. If both **SET20** and **SET4** are zero the analog output will stay about 3.85 mA and will not change with the rate. Press short **SET**. After a couple of seconds during which all the settings are checked, validated and stored into the non-volatile memory, the computer will return to the normal mode.

NOTE: The software time out feature will reset the computer and force it to the normal mode WITHOUT saving any changes made in any of the menus. The changes will only be saved after exiting the SET20 by pressing short SET.

NOTE: Even in menu mode, the computer always continues to measure and calculate rate and total and control the output so no total will be lost. In some circumstances, such as changing the KFACTOR, the total accumulated will be invalidated. The user must take



appropriate actions after changing the settings, such as resetting the total for an instance.

3.4.3.1. The Hidden Menu

This is a second level menu that offers more features and programming flexibility to trained professionals or more advanced users. The setting in the hidden menu are not affected by the lock/unlock of the settings in the first level menu.

To enter the hidden menu while in the KFACTOR menu, move the cursor (blinking digit) to the most right and then use long **SET** to enter the total volume units menu.

- Use **UP** to choose the **total volume units** among **mL**, **L**, **G**, **CF**, **M³** and **AF**. Press short **SET** to move to the **rate volume units menu**.
- Use **UP** to choose the **rate volume units** among **mL**, **L**, **G**, **CF**, **M³** and **AF**. Press short **SET** to move to the “**time unit menu**.”
- Use **UP** to choose the time units among **S** (per second), **M** (per minute), **H** (per hour) and **D** (per day). Press short **SET** to move to the **DI 200** menu.
- In the **DI 200** menu chose “**yes**” if the flow meter is a Data Industrial 200 series.
If “**yes**” has been chosen pressing short **SET** will enter the **SET4** menu.
If “**no**” has been chosen pressing short **SET** will enter the **CURvE** menu.
- In the **CURvE** menu, use short **UP** to change between blinking **CURvE** and blinking **KFACTOR**. The flow computer will use either the single **KFACTOR** or the calibration **CURvE** of up to 10 points for calculations. The points have to be entered before using the calibration curve. The factory default is 1.0 for the KFACTOR of each point. The curve is stored in a non-volatile memory, and the points can be entered in any order. The computer will order and validate them.
 - Enter the calibration data mode by using long **SET** in the **CURvE** menu for either a blinking **CURvE** or **KFACTOR**.
 - “**CAL Crv**” will appear on the LCD, and “**NO**” icon will be blinking. To continue choose **YES** and press short **SET**. To leave calibration curve data mode and leave the previous calibration data untouched, choose **NO** and press short **SET** to go back to the **CURvE** menu.

This feature is very useful for flow meters that have a calibration sheet provided by the manufacturer or the calibration laboratory. Each point consists of an input frequency in Hz and a KFACTOR for that frequency.

Once you enter the calibration curve data menu, you have to go to the last point (point 9). If you have data for less points enter 0.0 for the frequency for all unused points. The computer will not accept 0.0 for any KFACTOR.

If **YES** has been chosen, “**Point 0**” will appear on the LCD. Press short **SET** and enter the input frequency in Hz for point 0. Press short **SET** and then enter the KFACTOR for that input frequency. Press short **SET** to do the same for the next point.

Repeat the above for up to 9 more points. After point 9, the flow



computer will automatically return to the **CUrVE** menu.

- There is no need to enter the frequency at each point in a special (ascending/descending) order. The computer will automatically sort and validate the data and calculate all the parameters..

In the **CUrVE** menu press short **SET** to move to **SET4** menu.

- In the **SET4** menu the icon SET20 will be blinking showing the relation to **SET20** parameter. In this menu the flow rate (in **rate volume units per time unit**) for 4.00 mA of the analog output can be entered. The factory default is 0.00.

Use short **SET** to move to the next menu.

- Press short **SET** to move to the “Rate **decimal Places**” menu where (using short **UP**) auto, none, 1, 2, 3, 4 or 5 decimal places for the rate can be programmed.
- Press short **SET** to move to the “Total **decimal Places**” menu where (using short **UP**) auto, none, 1, 2, 3, 4 or 5 decimal places for all totals can be programmed.
- Press short **SET** to move to the **Total A Reset enable/disable** menu. In this menu using **UP** button the total A reset can be enabled or disabled.

If enabled and GFC114 is in normal mode displaying total A, the **RESET** icon will also be displayed and long **RIGHT** will clear total A.

Total B and C are non-resettable.

- Press short **SET** to go back to the **KFACTOR** menu on the first level.

3.5. Checking the LCD

All the icons of the LCD can be checked by pressing and holding the **RIGHT** button while powering on or after exiting the last menu. Releasing the button will return the computer to normal mode.

3.6. Removing the power

All totals are stored in the non-volatile memory every 50 seconds.
Before removing the power make sure that there was no flow for the last minute.

4. MENU DIAGRAM

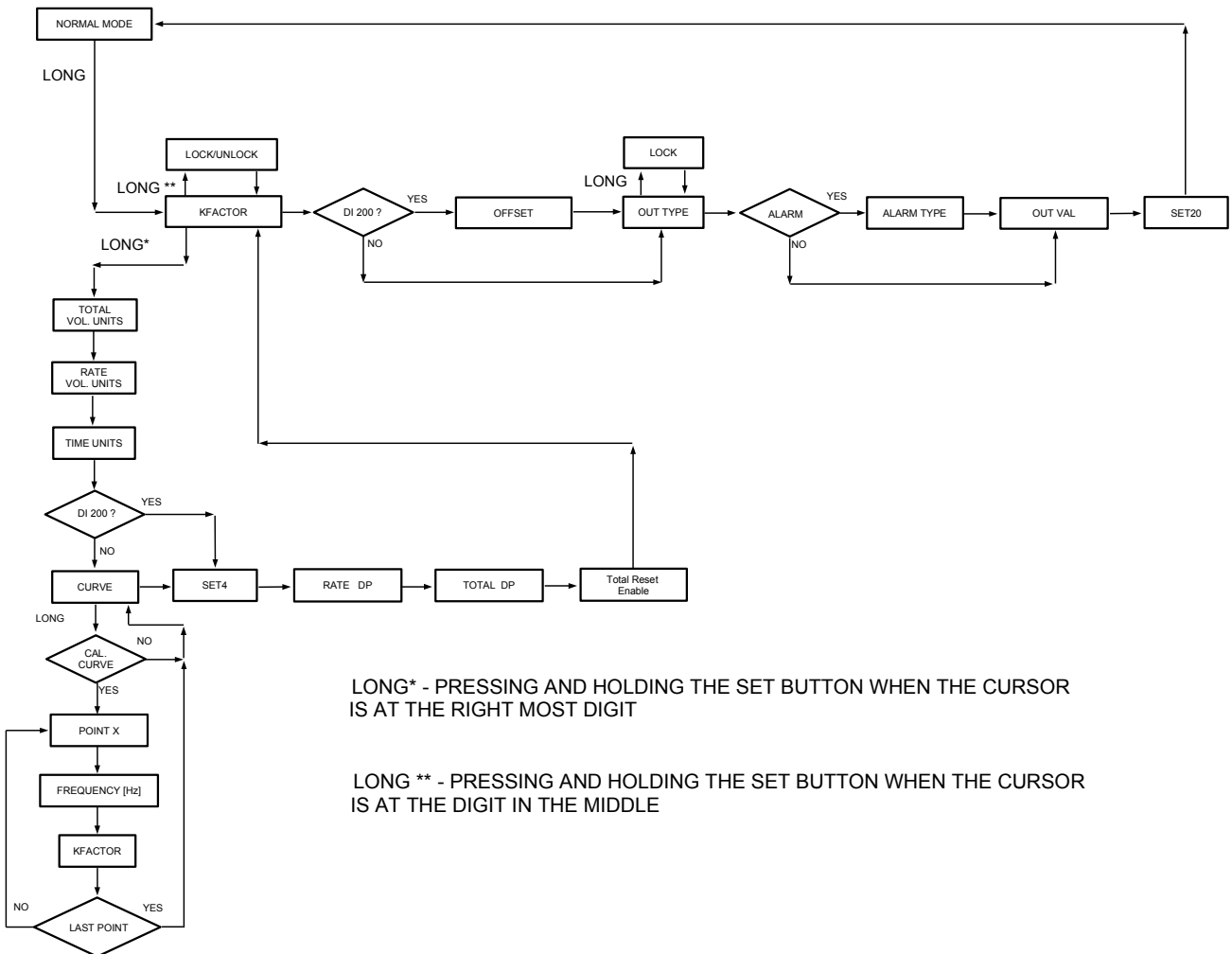

5. APPLICATION

5.1. ELECTRICAL

NOTE: There is no isolation between the sensor input, the power supply and the push button input. It is the user's responsibility to consider this fact and implement appropriate wiring in the user's specific application.

5.1.1. Wiring the sensor

GFC114 accepts a variety of sensors. See below their particular wiring:

5.1.1.1. NPN Open Drain, Open Collector

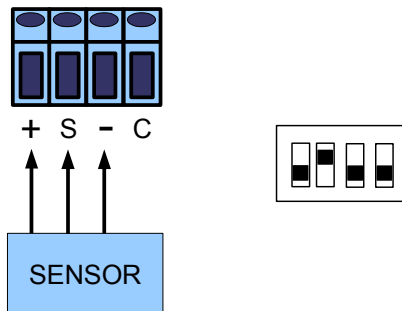

5.1.1.2. PNP Open Drain, Open Collector

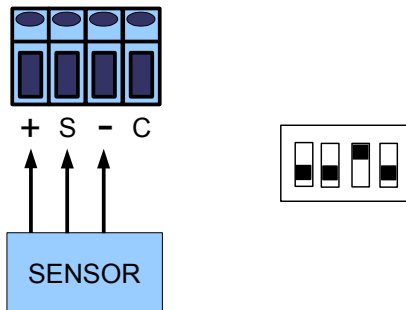

5.1.1.3. Reed Switch, Dry Contact

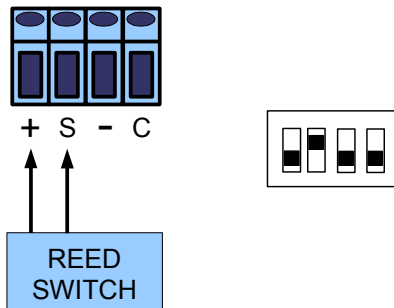

NOTE: Different reed switches and dry contacts have different bouncing time. Test and evaluate carefully to determine the right DIP switch setting.

5.1.1.4. Wave (square, sine, triangle, saw etc.), Logical Signal (CMOS, TTL etc.)

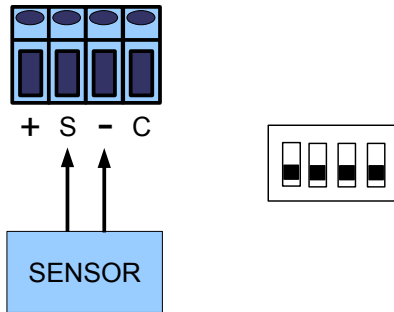

5.1.1.5. NAMUR Sensors, Data Industrial Two Wire Flow Meters

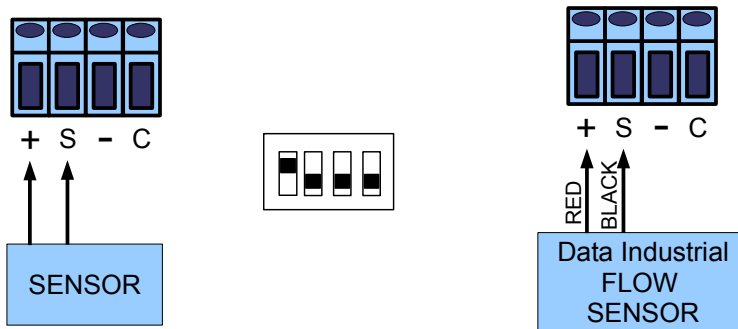

5.1.1.6. Coils

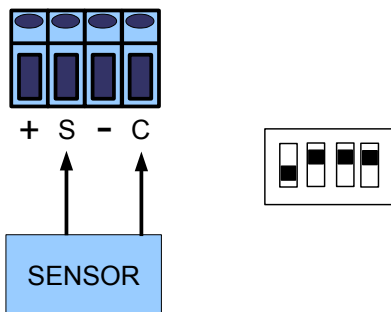

NOTE: If the cable to the coil is shielded, connect the shield to “-” (terminal 5) ONLY. Do not connect the shield to anything at the other (coil) end of the cable. The shield has to be isolated from earth ground and all other equipment or electrical connections.

5.2. VERSIONS



WALL MOUNT GFC114



WALL MOUNT GFC114E

6. ORDERING

For ordering please use the following G Instruments part numbers:

<i>Description</i>	<i>G Instruments PN</i>
GFC114 flow computer, no power supply (external isolated 12 – 36 V DC needed)	30156
GFC114 flow computer with GPS115 (115 VAC power supply)	30157
GFC114 flow computer with GPS220 (220 VAC power supply)	30169
GFC114 flow computer with GPS122 (85-264 VAC power supply)	30232
GFC114E flow computer, no power supply (external isolated 12 – 36 V DC needed)	30165
GFC114E flow computer with GPS115E (115 VAC power supply)	30182
GFC114E flow computer with GPS220E (220 VAC power supply)	30172
GFC114E flow computer with GPS122E (85-264 VAC power supply)	30173



IMPORTANT NOTICE

G Instruments reserves the right to make corrections, modifications, enhancements, improvements and other changes to its products at any time without notice.

Customers should obtain the latest relevant information before placing orders and should verify that such information is current and complete.

G Instruments does not assume any liability arising from the use of any device or circuit described herein, nor does it convey any license under its patent rights or the rights of others.

Customers are responsible for their products and applications using G Instruments devices. To minimize the risks associated with customer products and applications, customers should provide adequate design and operating safeguards.

G Instruments products are not authorized for use as critical components in life support devices or systems without express written approval of G Instruments.

Trademarks and registered trademarks are the property of their respective owners.